

Color Notes

COLOR INDEX

- PLOT BOUNDARY
ABUTTING ROAD
PROPOSED WORK (COVERAGE AREA)
EXISTING (To be retained)
EXISTING (To be demolished)

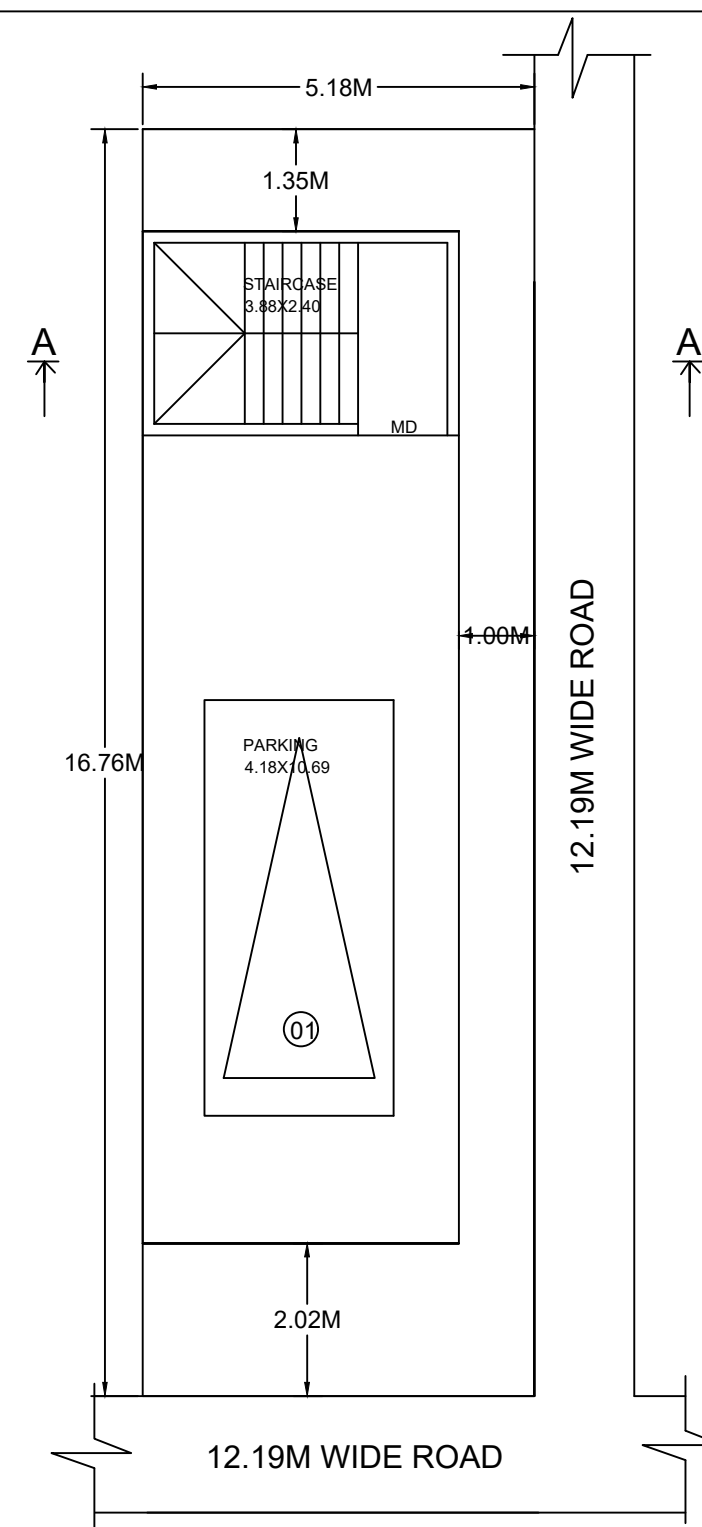

STILT FLOOR PLAN

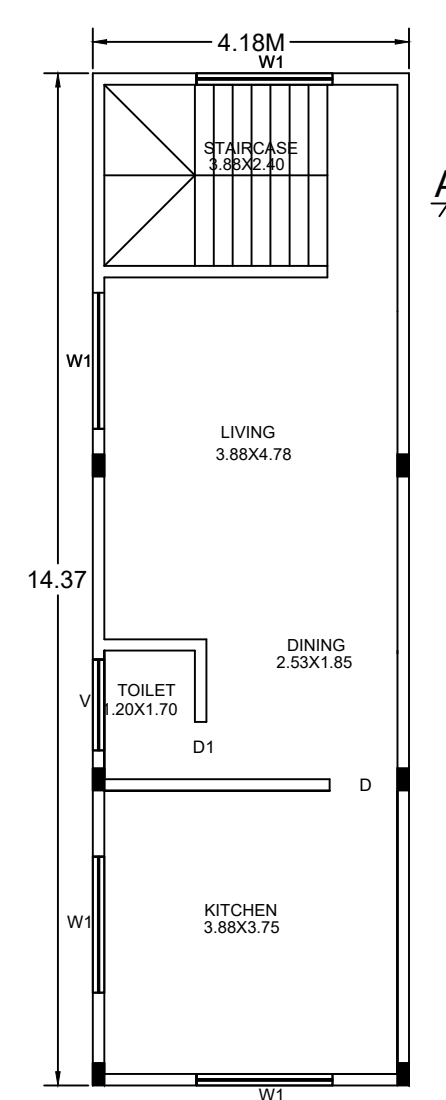

GROUND FLOOR PLAN

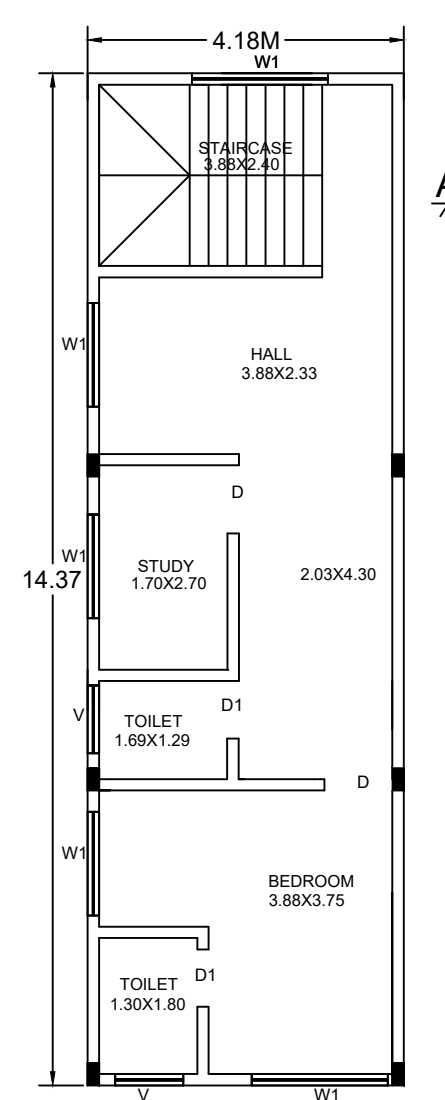

FIRST FLOOR PLAN

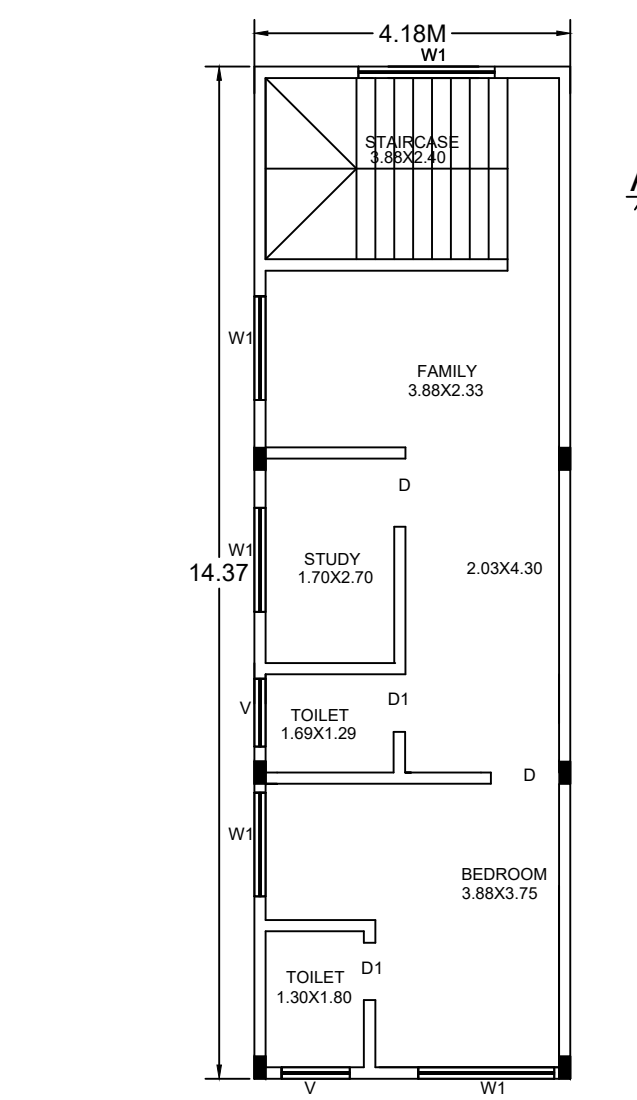

SECOND FLOOR PLAN

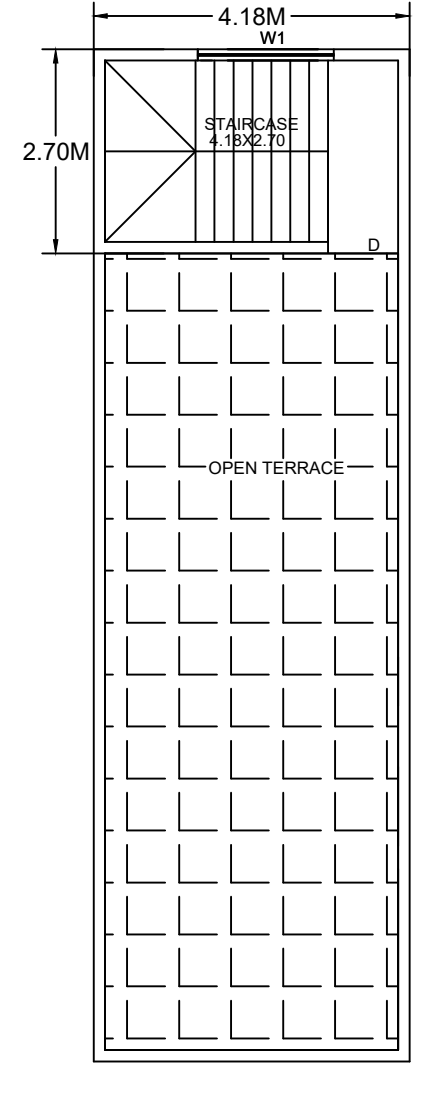

TERRACE FLOOR PLAN

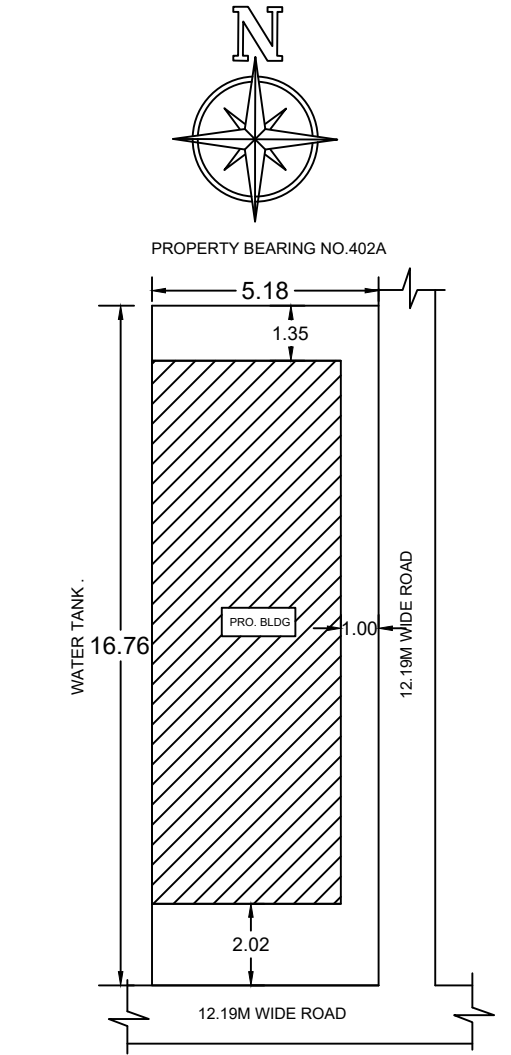

SITE PLAN

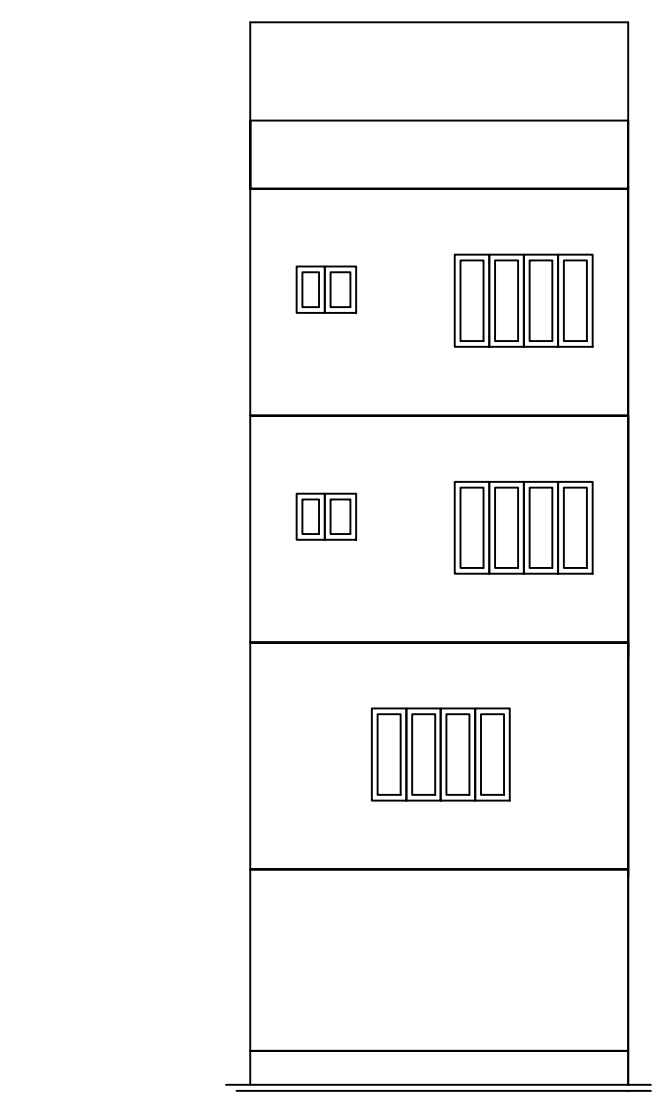

FRONT ELEVATION

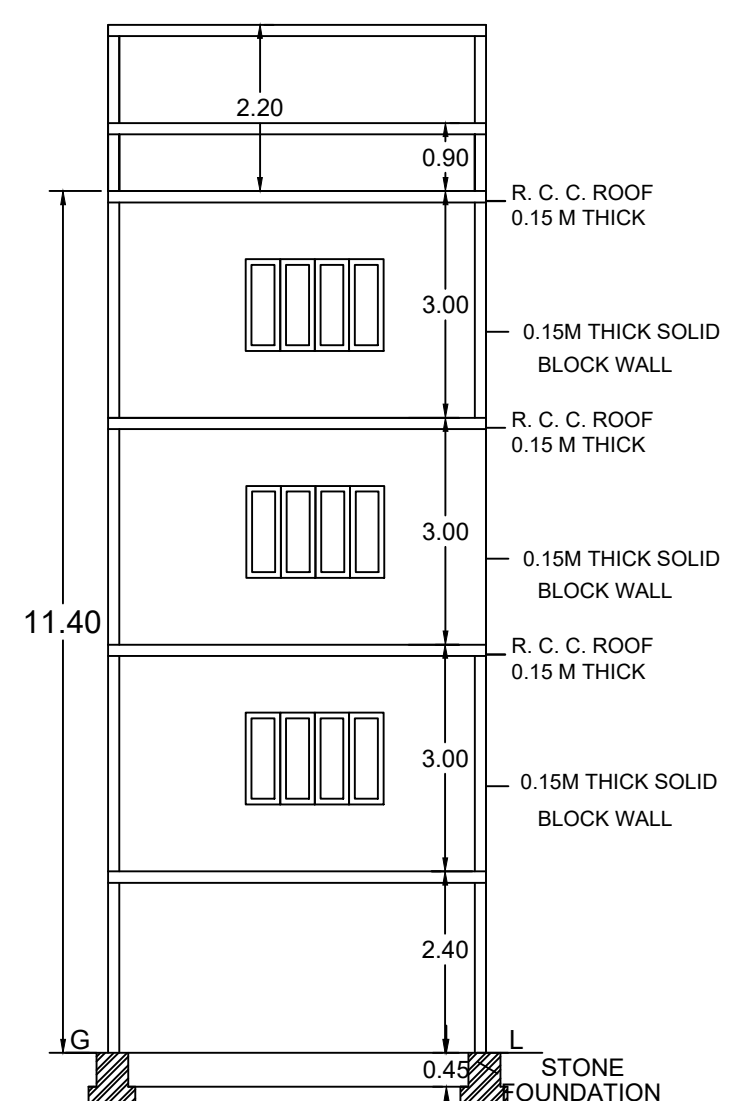

SECTION AT A-A

Approval Condition: This Plan Sanction is issued subject to the following conditions:
1. The sanction is accorded for...
2. The sanction is accorded for Plotted Resi development A (A) only...
3. Car Parking reserved in the plan should not be converted for any other purpose...
31. Sufficient two wheeler parking shall be provided as per requirement.
32. Traffic Management Plan shall be obtained from Traffic Management Consultant for all high rise structures...

Table: Block :A (A) with columns: Floor Name, Total Built Up Area (Sq.mt.), Deductions (Area in Sq.mt.), Proposed FAR Area (Sq.mt.), Total FAR Area (Sq.mt.), Tnmt (No.)

Table: UnitBUA Table for Block :A (A) with columns: FLOOR, Name, UnitBUA Type, UnitBUA Area, Carpet Area, No. of Rooms, No. of Tenement

Table: FAR & Tenement Details with columns: Block, No. of Same Bldg, Total Built Up Area (Sq.mt.), Deductions (Area in Sq.mt.), Proposed FAR Area (Sq.mt.), Total FAR Area (Sq.mt.), Tnmt (No.)

Table: SCHEDULE OF JOINERY with columns: BLOCK NAME, NAME, LENGTH, HEIGHT, NOS

Table: SCHEDULE OF JOINERY with columns: BLOCK NAME, NAME, LENGTH, HEIGHT, NOS

Table: Parking Check (Table 7b) with columns: Vehicle Type, No., Area (Sq.mt.), No., Achieved Area (Sq.mt.)

Table: Block USE/SUBUSE Details with columns: Block Name, Block Use, Block SubUse, Block Structure, Block Land Use Category

Table: Required Parking (Table 7a) with columns: Block Name, Type, SubUse, Area (Sq.mt.), Units, Car, Prop.

Table: AREA STATEMENT (BBMP) with columns: AREA OF PLOT (Minimum), AREA OF PLOT, NET AREA OF PLOT, COVERAGE CHECK, FAR CHECK, BUILT UP AREA CHECK

Approval Date:

OWNER / GPA HOLDER'S SIGNATURE: SRI S HAREESH KUMAR REDDY, AMRUTHAHALLI VILLAGE, TALAKAVERI NAGARA, YELAHANKA HOBLI, BANGALORE.

ARCHITECT/ENGINEER /SUPERVISOR'S SIGNATURE: KIRAN KUMAR DS NO.338, Talakaveri Inavrut Amruthahalli, Bangalore-92, Mob:9538654099 e-41992016-17

PROJECT TITLE: PLAN SHOWING THE PROPOSED RESIDENTIAL BUILDING AT SITE NO:402B,KATHA NO:746/1060/746/402B,AMRUTHAHALLI VILLAGE,TALAKAVERI NAGARA,YELAHANKA HOBLI,WARD NO:07,BANGALORE.

DRAWING TITLE: 1234642130-12-04-202104-51-35S_SHARISH KUMAR REDDY 12 : : A) with STILT, GF+2UF

SHEET NO : 1

Table: SANCTIONING AUTHORITY with columns: ASSISTANT TOWN ENGINEER / TOWN PLANNER, ASSISTANT DIRECTOR, YELAHANKA